

MEKI™

MEKI™. Excelling in X-ray food inspection

The options for foreign object inspection in the food industry have long been limited. Until now there were only simple metal detectors on one hand and high-price X-ray systems on the other. With MEKI, you finally have the choice.

MEKI™. Revolutionary in every aspect

MEKI is an automated product quality control system using the latest X-ray image processing technology. MEKI images the inside of food products and detects foreign objects such as metal, stones, glass, bones as well as dense plastics. MEKI simultaneously performs several different analysis, such as shape, weight or content inspection. Even high moisture, salt content or packaging materials containing metal are not a problem. To make it a perfect fit, MEKI requires the least amount of installation space in the product line compared to any other X-ray device.

MEKI compares favorably with any other X-ray inspection system, yet it only requires an investment similar to the one of a metal detector.

MEKI™. Makes X-ray inspection affordable

The most significant factors in the price of an X-ray based quality control system are the detector and X-ray generator. Unlike all the other X-ray systems producers, our roots are in the design, manufacture and optimization of these key components. This enables us to greatly reduce our costs, so we can pass the savings on to Mekitec's most valuable asset – our customer.

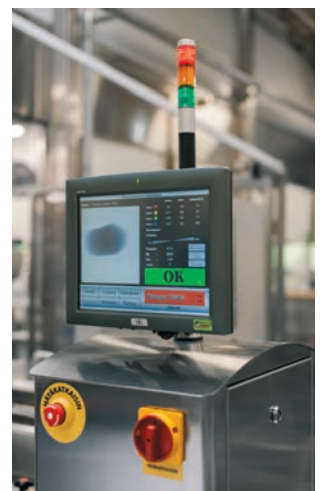

TECHNICAL SPECIFICATIONS

The world's smallest X-ray food inspection system

Detection area	9.84" × 4.33" (250mm × 110 mm)
Conveyor speed	min 0.3 ft/s (0.1 m/s) max 4.3 ft/s (1.3 m/s)
X-ray power	40–60 kVp / 0.1–2.5 mA (<100 W)
X-ray leakage	Less than 1 μSv/h
Detector type	Linear scanner, width 10" (256mm)
Pixel size	0.4mm
Operating system	Windows 7
Software	Mekitec X-ray Inspection System SW
Power supply	110–240 VAC, 50–60 Hz
Operation temperature	32–95°F
Dimensions (w × d × h)	32"/47" × 20" × 79" (800/1200×515×2000 mm)
Weight	165 lbs
Connection to data	Ethernet/USB



Industries

MEKI is perfect for quality control in the following food sectors:

- meat and poultry
- fish
- vegetables and fruits
- bakery
- dairy
- confectionery
- flavoring
- ready meals
- chewing tobacco

Applications

MEKI is particularly suitable for the inspection of

- packaged products
- small and medium sized products

For applications such as unpacked and bulk products, trays with several products or multiple lines of small products, please refer to the datasheets MIDMEKI.

Dimension of inspected goods

Height	Width
4"(100mm)	5.8"(148mm)
3.2"(80mm)	6.6"(168mm)
2.4"(60mm)	7.4"(189mm)
1.6"(40mm)	8.3"(210mm)
0.7"(20mm)	9.1"(230mm)

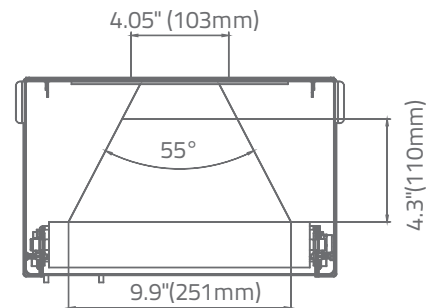

Contact us

Mekitec Ltd., info@mekitec.com, www.mekitec.com